

# Ground Light

Series Type: GB-G108A-NF

## Features 產品特點 >>

- The LED ground light is ideal for both domestic and commercial applications
  - The protection grade is IP67, waterproof and dust proof, safe to use
  - Stable performance with built-in constant current driver,
  - Made by stainless steel and aluminum, the lamp can be protected perfectly.
  - It's perfect for outdoor lighting such as landscape, garden, path, yard, etc
- LED地面燈是家庭和商業應用的理想選擇
  - 防護等級為IP67, 防水防塵, 使用安全
  - 內置恆定電流驅動器, 性能穩定
  - 燈由不銹鋼和鋁製成, 可以得到完美的保護
  - 非常適合戶外照明, 例如景觀, 花園, 道路, 院子等



Flick Free  
(無閃頻)  
保護視力

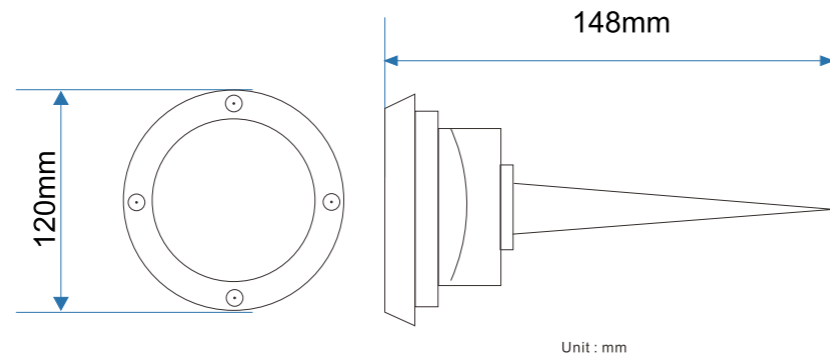

## Specification 產品規格 >>

Model 型號	Voltage 電壓	Wattage 功率	Size 尺寸	Lamp Life 光度壽命	Colour Temp 色溫	Lumen Output 輸出流明	Color Rendering 顯色度	Beam Angle 光速角度	Operating Temperature 工作溫度
	(V)	(W)	(mm)	(Hrs)	(K)	(Lm/W)	(CRI)	(°)	(°C)
GB-0303-G108A-NF	85-265	3	Ø120*148	50000	3000/4000/6500	100	>80	30	-20~+45

- Light efficiency (lm/W), Power (W) Can be customized according to customer needs
  - This type of certification is issued by a government-approved laboratory for Safety certification, Fire testing, Restriction of Hazardous Substances (RoHS), Photobiological safety of lamps and lamp systems. (an Exemption Group) and other test certifications to ensure product quality
- 光效 (lm/W)、功率 (W) 可根據客戶需求定制
  - 此型號認證由可實驗室發出之安全認證消防測試, 環保物料 (RoHS), 光生物安全為Exemption Group及其它測試, 保證客戶使用更安心滿意

# Under Water Light

水底燈